

Application Techniques for Avery Dennison Reflective Traffic Sign Pressure-Sensitive Sheeting

*Instructional Bulletin #8.10
Issued: June 6, 2008*

Introduction

Before starting application consult the appropriate product data bulletin for information regarding minimum and maximum application temperatures, recommended substrates, and immediate service conditions before and after application. These factors are critical to a successful application and future sign performance. Once assured that all factors are understood with respect to the product, and all factors comply with the product recommendations, cleaning and surface preparation can begin.

NOTE: Documentation of application date, material lot number, and application conditions (temperature, etc.) is required to support warranty claims in the event of sign failure.

1.0 Application Procedure for Roller Laminating

Squeeze roll applicators are designed for continuous or individual application of Avery Dennison reflective sheeting to sign bases described in IB # 8.01. Carefully read and follow all practices outlined in this bulletin and in manufacturer's literature for accurate results.

Many machine options are available depending on your needs. Contact the machine manufacturer or an Avery Dennison technical representative for further information.

Safety and Handling

Refer to the Material Safety Data Sheet and all product instruction manuals for comprehensive information on the safety and handling of all products and equipment prior to use. When working with any equipment or machinery use appropriate safety equipment such as safety glasses, gloves, etc.

Avery Dennison assumes no responsibility for injury or damages that arise from the use of a product manufactured by another company.

Operating Procedures

Before applying Avery Dennison Reflective Sheeting, the surface of the substrate must be totally free of any contamination. Application must be made at room temperature, above 65°F (18°C). All materials must be acclimated before processing.

Fluorescent products are sensitive to incidental contact that can cause a defect to the sheeting. Take care not to fold the sheeting to a point that will create a material stress crease. Also, the lamination roll must be smooth. Dirt or debris on the lamination roll may create a blemish to the sheeting. Keep the original protective packaging on the roll. Remove it only after the roll has been loaded on to the squeeze roll applicator, and retain the protective packaging, and return it to the balance of the unused roll if returning to inventory.

Manual Squeeze Roll Applicators

These applicators are driven by a hand crank and can be run by one or more operators. They are intended for the individual application of signs.

Laminating Gap Adjustment

This procedure may vary from application to application depending on such factors as flatness, material thickness, and type of substrate.

When common materials are being used, keep a record of the optimum settings to duplicate during future runs.

1. Raise the top roller to create a gap larger than the thickness of the substrate.
2. Place the substrate between the opened laminating rollers.
3. Slowly lower the top roller until it evenly touches the substrate from edge to edge. Continue to lower the roller one-half turn to obtain adequate pressure.

Application Start-up

1. With the sheeting face down, peel back one to two inches of the release liner, folding it to expose the adhesive.
2. Turn the sheeting over and carefully align the sign face with the substrate. Press the exposed adhesive side down slowly onto the substrate. Work from the center towards the outer edges.
3. Feed the adhered section into the squeeze roller up to the folded portion of the release liner.
4. Drape the remaining sheeting over the top roll and peel back the remaining portion of the release liner, while feeding in the remainder of the sign blank (See Fig. 1).
5. Carefully trim all excess material downward at an angle with a sharp utility blade. Make sure to not chip or damage the sheeting.

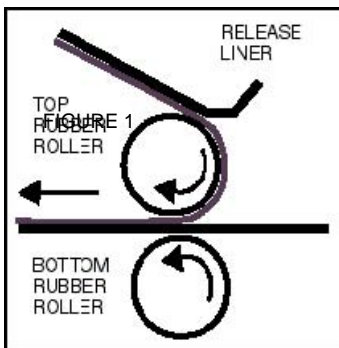

2.0 Automated Squeeze Roll Applicators

These applicators are driven by a motor and require two or more operators to run. They are used for continuous application of Avery Dennison sheeting to sign bases such as flat panels, extruded panels, and applications requiring heat.

Laminating Gap Adjustment

This procedure may vary from application to application depending on such factors as flatness, material thickness, and type of substrate.

When common materials are being used, keep a record of the optimum settings to duplicate during future runs.

1. Make sure the motor is not running. Raise the top roller to create a gap larger than the thickness of the substrate.
2. Place the substrate between the opened laminating rollers.
3. Slowly lower the top roller until it evenly touches the substrate from edge to edge. Continue to lower the roller one-half turn to obtain adequate pressure.

Note: Do not allow the rollers to rest against each other for prolonged periods of time. This can cause permanent flat spots which can adversely effect the laminating process.

Machine Set-up

It is recommended that all materials be centered on the machine. For better tracking and centered roll wear, always center your blanks in the middle of the laminating rolls.

1. Remove the unwind shaft from the machine and also remove the collars from the shaft.
2. Insert the core of sheeting over the shaft. The sheeting should unwind with the liner side in the up position.
3. Insert the collars with a light rubber mallet until the ridges grip the core. Do not telescope or damage the edge of the sheeting.
4. Place the shaft and sheeting onto the machine. Center the sheeting on the shaft and lock it into place using the set screws.
5. Place an empty core at least as wide as the unwind core, on the rewind shaft. Center it with the stock roll.

Note: Do not exceed 100 yards of release liner on a core.

6. Thread the sheeting under the stripper bar and up to the rewind core. If applicable, raise the stripper roller to the "up position" for T-5500A

7. Set the tension to prevent the stock roll from moving. Separate a few inches of release liner and tape it to the core. It must be centered and appear flat with no visible wrinkles.

Note: Start by taping the center and work out towards the ends. This will create even tension across the web.

8. Reduce the tension and start the machine. Allow the sheeting to drape over the top roll and below the nip point.

9. Align all edge guides so the blanks run in the center of the sheeting. Make sure edge guide alignment allows for panel variation.

Note: Roll good widths allow for approximately 1/8" sheeting overlap.

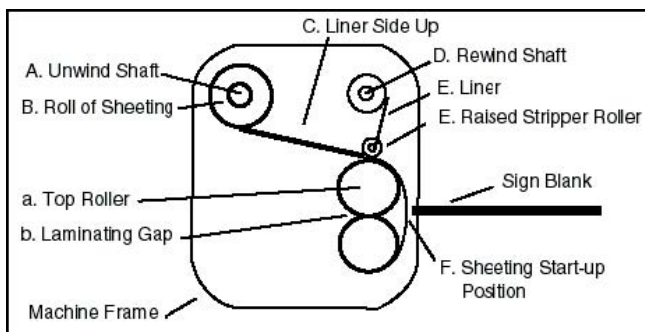

FIGURE 2

Application Start-up

1. Use a starter panel to guide the sheeting into the nip rollers. The panel should be a little larger than the width of the sheeting and 10" to 12" in length.

2. Insert the starter panel against the hanging sheeting and up against the nip point. Engage the drive and allow the panel to draw the sheeting between the nip rollers.

3. Adjust the tension to create a small loop as shown in Figure 3. This loop may occasionally disappear and reappear.

This loop must be maintained throughout the run.

4. Place a prepared sign blank behind the starter panel to keep the process moving. Each new panel should have a 1/4" gap. If the gap is too large the sheeting may adhere to the bottom roller.

Note: If the sheeting does adhere to the bottom roller, it should be removed as soon as possible to prevent build-up.

5. Carefully determine a productive lamination speed. T-5500A material is capable of running at most laminator speeds. Ideally material should be laminated anywhere from 8-12 fpm. It is important that the operator be aware of the speed, as this will also determine the amount of heat the edge heaters place on the material.

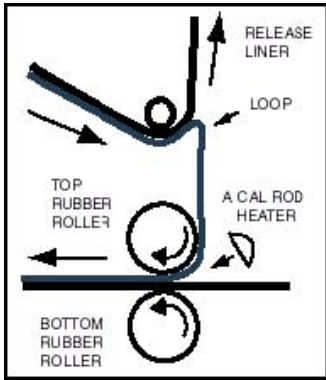

Note:

- Do not allow the sheeting to be applied at high tensions.
- If a large loop is maintained the sheet may wrinkle.

FIGURE 3

6. Carefully trim all excess material downward at an angle close to the panel edge with a sharp utility blade. Make sure to not chip or damage the sheeting.

7. Place all applied materials on edge indoors until ready to ship.

Warning: Do not touch the rollers unless the machine is stopped and the power is off. Rotating rolls are dangerous: Do not wear loose clothing, jewelry, etc. when operating equipment.

When applying Avery Series T-5500A High Intensity Sheeting to HDO Plywood, careful attention must be paid to the following steps:

- Squeeze Roll Applicator must be used to apply the proper amount of pressure to the substrate. Hand application is not an acceptable method of applying T-5500A Sheeting to an HDO substrate.
- The use of a cal-rod is required for the lamination of T-5500A Sheeting to an HDO substrate. The steps for setting up the cal-rod are as follows:

Pre-heated Application Start-up

The use of a cal-rod heater bar is required only when applying to approved overlaid plywood substrates. **Do not use heat when running aluminum substrates.**

Caution:

- Do not touch the heating elements when the electrical power is connected. This may cause serious injury.
- Do not allow the sheeting or liner to come in contact with the heater while it is hot.

The use of a teletemp strip placed on the stock roll of sheeting will record the temperature as the laminated sheeting passes under the heater.

1. Position the cal-rod heater at the sheeting/blank intersect.
2. Pre-heat the rollers approximately 5 minutes or until they are warm.

Caution: Do not allow the heaters to be aimed at the sheeting or rollers if they are stationary.

3. The recommended temperature of 110°F(43°C) can be obtained by adjusting the line speed. Start the applicator operating at 12ft/min (3.7m/min) adjust as necessary.
4. Continue to run according to "Application Start-up" section 1.

Extrusions

Extruded street sign panels may be laminated with a fitted piece of rubber properly secured around the top roll. This will allow the sheeting to conform into the channel in the extruded street sign blank.

When processing special aluminum extrusions (12" extrusions and other panels where sheeting may be edge wrapped), side heaters and edge wrappers are required.

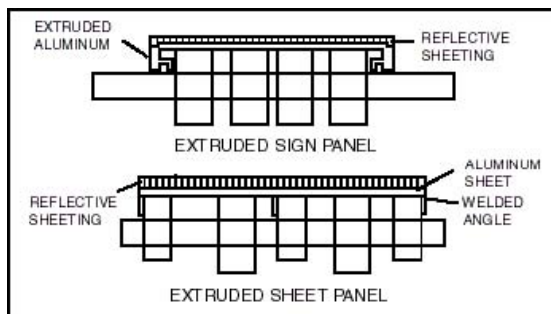

FIGURE 4

For glass beaded sheeting (T-1500, T-2500, and T-5500), the edge heaters and wrappers should laminate the sheeting down the sides of the extruded panel. It is important to use edge heaters prior to edge wrapping the material. Typically the temperature of the edge heaters should be between 100-105 F. The edge heaters purpose is to slightly soften the material, so that during edge wrapping the material does not break or crack. It is important to test the pressure of the edge rollers for constant pressure along the sheeting. A good starting point for beaded sheeting is 40-50 psi of pressure on the edge rollers.

It is also important to recognize defects that are caused by too much or not enough heat from the edge heaters. Close observation needs to be taken around the edges of the panels. Defects that occur are wrinkling, bubbling and edge popping if too much or not enough heat is utilized.

For prismatic sheeting (T-6500 & T-7500), it is highly recommended that any panels not butted together (exposed edges) in the final assembly process (having exposed edges) be edge trimmed flush with the sign face surface to eliminate edge

lifting of the sheeting or scored along the corner edge so that any lifting of the edge strip will not propagate to the face of the sign. In case of 12" extrusions, exposed edges would be the top edge of the top panel, and the bottom edge of the bottom panel. **(See Below Pictures for trimming technique)**



Trimming Technique for exposed top and bottom edges

While prismatic sheeting (T-6500 & T-7500) normally can be edge wrapped successfully with the use of edge heaters and wrappers, it is the sign fabricator's responsibility to insure that satisfactory adhesion is obtained. Avery Dennison will not be responsible for any edge lifting of the prismatic sheeting. It is important to test the pressure of the edge rollers for consistent pressure along the sheeting. A good starting point for prismatic sheeting is 50-60 psi of pressure on the edge rollers.

While laminating T-6500 & T-7500 sheeting to extrusion panels, there are several settings and conditions that need to be followed to obtain quality extrusion panels. Initially the nip of the extrusion laminator needs to be set with the extrusion blank along with the material in the nip. The nip roller should have a 70 durometer.

See IB # 8.01 for properly prepared approved sign extrusion.

Important:

- The sheeting must be cut to the correct width, the sheeting should be positioned to allow equal overhang on both edges of the extrusion.
- Extreme care must be taken to insure that the panel edges as well as the panel surface are clean from any contaminants to insure proper bonding of the sheeting to the wrapped edges.
- Edge heaters must be turned off if the operation is stopped.

Shut-down

When you are finished running any of the above methods and are ready to turn off the applicator, the following guidelines should always be followed:

1. Never allow the sheeting to rest under the rollers for prolonged periods of time. This may cause a flat spot in the rollers or damage the reflectivity.
2. Leave a space between all rolls. Rolls that are in contact with each other may develop flat spots.
3. Never cut the sheeting against a roller. Loosen the tension to allow slack in the sheeting before cutting.
4. When removing material from the applicator, always rewind enough liner to use as a leader during future use.

3.0 Application Procedures for Hand Laminating

“Small Decals” - No special techniques are required. Simply peel off the backing paper, position, and press down with finger pressure.

“Large Decals” - Use the Center Hinge Method

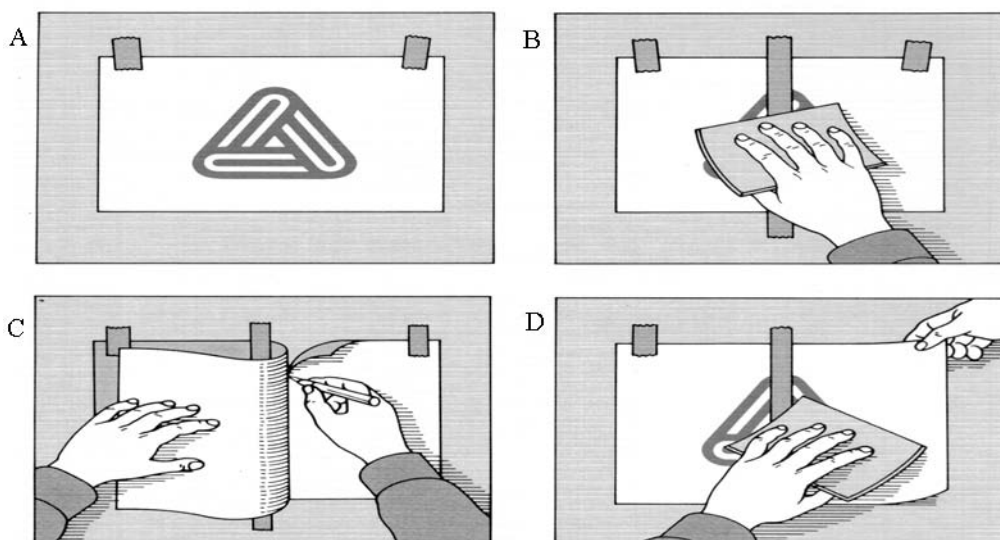

Center Hinge Method

1. Apply pieces of masking tape to the sheeting as shown above. (Refer to illustration A.) This will help facilitate positioning on the substrate.
2. Apply a strip of tape as a hinge in the center of the sheeting. Overlap each edge. (Refer to Illustration B.)
3. Fold one-half of the sheeting back on the hinge, then cut through the backing paper and remove. (Refer to Illustration C.)
4. Without touching the adhesive, apply this portion of the sheeting to the substrate, using a squeegee. Use overlapping strokes and work from the hinge to the edge. (Refer to Illustration D.)
5. Remove the center hinge tape and repeat Steps 1 through 4 on the other half of the sheeting.

6. Puncture any air bubbles with a size/no. 20 – 1.25 in. (3.2 cm) ball point pin and re-squeegee. Do not use a razor blade to puncture air bubbles, as the slit may eventually gap and tear.

4.0 Handling of Signs

Mark signs with the appropriate manufacturing information so that the signs may be tracked and identified at a later date.

Package signs face-to-face and back-to-back placing slip sheeting (silicone side of liner) against each sign face and put a non-permeable separator (such as a piece of plastic) between signs.

Store and ship signs on edge-on-edge in a moisture-free environment. Avoid packaging methods, which will result in heavy pressure on the face of the signs.

If the sign packaging becomes wet, remove the signs, thoroughly dry off and repackage with dry materials.

Avery Dennison's liability for defective products shall not exceed the purchase price paid therefore by Purchaser and in no event shall Avery Dennison be responsible for any incidental or consequential damages whether foreseeable or not, caused by defects in such product, whether such damage occurs or is discovered before or after replacement or credit, and whether or not such damage is caused by Avery Dennison's negligence.

NO EXPRESS WARRANTIES AND NO IMPLIED WARRANTIES, WHETHER OF MERCHANTABILITY OR FITNESS FOR ANY PARTICULAR USE, OR OTHERWISE (EXCEPT AS TO TITLE), OTHER THAN THOSE EXPRESSLY SET FORTH ABOVE WHICH ARE MADE EXPRESSLY IN LIEU OF ALL OTHER WARRANTIES, SHALL APPLY TO PRODUCTS SOLD BY AVERY DENNISON. AVERY DENNISON SPECIFICALLY DISCLAIMS AND EXCLUDES ALL OTHER SUCH WARRANTIES. NO WAIVER, ALTERATION, ADDITION OR MODIFICATION OF THE FOREGOING CONDITIONS SHALL BE VALID UNLESS MADE IN WRITING AND MANUALLY SIGNED BY AN OFFICER OF AVERY DENNISON..

Avery Dennison, 7542 N. Natchez Ave, Niles, IL 60714 USA
www.reflectives.averydennison.com